

## DATA SHEET

For the most current version visit [www.phantomhighspeed.com](http://www.phantomhighspeed.com)  
Subject to change Rev August 2016

# Phantom® VEO Product Family

Performance high-speed imaging with models that range from 3Gpx/sec to 7Gpx/sec throughput.

Features include Programmable I/O, CFast 2.0 media\*, SDI and HDMI video outputs, a large recording buffer and a compact design.

### Key Features:

Memory: 18GB, 36GB or 72GB RAM

Exposure: Minimum exposure is 1  $\mu$ s on all models; 300 ns exposure time on VEO 710 with FAST option (export controlled). All models support Extreme Dynamic Range (EDR), Auto-Exposure, and Shutter-Off mode for PIV.

Available in four performance levels:

- VEO 340: 2560 x 1600 @ 800 fps
- VEO 410: 1280 x 800 @ 5200 fps
- VEO 640: 2560 x 1600 @ 1400 fps
- VEO 710: 1280 x 800 @ 7400 fps

Available in two body styles: L and S

Size: Approximately a 5" (13cm) cube (not including lens mount)

Rugged design: High-G Rated (non-destructive up to 100G); Milled aluminum housing with electronics isolated from airflow

\*available on S-models



VEO710S and 340L

### Introducing the Phantom VEO

Designed to perform in a wide array of scientific and industrial applications, Phantom VEO high-speed cameras provide valuable insight into events that are too fast to be seen with traditional imaging technology. With frame rates that exceed 7,000 frames-per-second (fps) at **one-megapixel**, VEO 710 and 410 models are perfect for traditional high-speed motion analysis and the **four-megapixel** VEO 640 and 340 models are ideal for scientific imaging and where higher resolutions are important.

Phantom VEO cameras go beyond these basic specs with two body styles: Choose the **'L' model** for basic, software-based imaging in a lab or office environment. Choose the **'S' model** to take advantage of additional signals, on-camera controls for un-tethered and remote recording, ruggedized connectors and compatibility with removable CFast 2.0 storage media.

These four performance levels and two body styles allow users to **choose the best configuration** for their project in terms of both features and budget.

## Phantom VEO

Phantom VEO cameras are packed full of features to enable a variety of applications, including:

- Material analysis
- Fluid dynamics
- Microfluidics
- Biomechanics
- Combustion studies
- Ballistics
- Off-board automotive
- Airbag testing
- Impact studies
- Defense R&D
- Special effects
- Un-tethered workflow
- Specialty rigs

### Specifications and Features:

**Video monitoring:** Front 3G HD-SDI, HDMI & VF power available on all models. Additional rear 3G HD-SDI port on S models. Provides the following video signals: 720p 50, 59.97, 60; 1080i 25, 29.97, 30; 1080psf 23.976, 24, 25, 29.97, 30; 1080p 23.976, 24, 25, 29.97, 30, 50, 59.97, 60.

**Connectivity:** Gb Ethernet for control and download. Fixed Trigger and Timecode-in ports. **Programmable I/O** is available on all models, and enables the ability to assign and define the parameters of various signals including: F-Sync, Strobe, Event, Pre-trigger, Memgate, Timecode-out, Ready, Aux Trigger and Auto-Trigger output.

**Timecode:** IRIG in/out, SMPTE and MISP time system support.

**Multi-Cine:** Partition internal RAM, into up-to 63 segments and capture quick recordings back-to-back. Supports Seamless-Cine-Switching to ensure no frames are missed. RAM is available up-to 72GB.

**Image-Based Auto Trigger (IBAT):** Trigger the camera (or even a number of connected cameras) from motion detected within the live image. This makes it possible to catch unpredictable events without manually triggering the camera.

**Internal Mechanical Shutter:** Shutter closes quickly to perform a black reference or to protect the sensor while changing lenses. No physical access to the camera is needed.

**Quiet Fans:** Turn the fan off temporarily to eliminate noise and vibration.

**Lens Mounts:** Interchangeable. Supports Nikon F/G, Canon EF with electronic control of aperture and focus, 35mm PL and C-mount.

### Accessories

(from Vision Research and third parties)

- Cheese plate: Adds multiple mounting points for accessories on top, bottom and right side
- Basic handle: Compatible with and without cheese plate
- Optical Low Pass Filter (OLPF) for color 640 and 340 models
- Cine-style accessories, riser, recommended monitors, viewfinders, and battery solutions available soon



Cameras pictured with cheese plate and basic handle configurations

## Imaging Specifications:

640 & 340 models	710 & 410 models
Resolution 2560 x 1600	Resolution 1280 x 800
Pixel Size: 10 micron	Pixel Size: 20 micron
Sensor size: 25.6 x 16mm	Sensor size: 25.6 x 16mm
ISO Mono: 16,000T, 6400D Color: 1250T, 1250D	ISO Mono: 16,000T, 6400D Color: 2000T, 2000D
Adjustable E.I. * Mono E.I. 6400 – 32,000 D Color E.I. 1250 - 6,400	Adjustable E.I. * Mono E.I. 6400 – 32,000 D Color E.I. 2000 – 10,000 D
12-bit pixel depth	12-bit pixel depth
Global Shutter	Global Shutter

ISO measured according to ISO 12232:2006 method

\* Recommended Exposure Index (E.I.) range is specified. Set with On-camera controls or PCC software. Higher EI settings are possible using gain and other image tools.

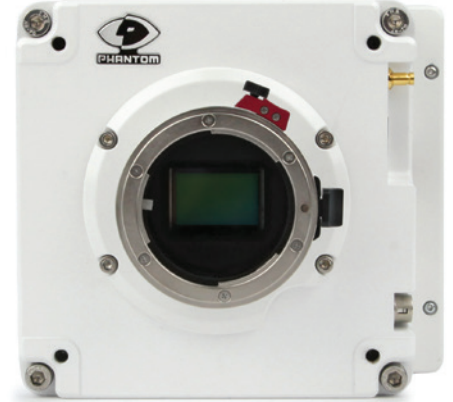

## Camera Control & File Formats

**Software:** Phantom Camera Control software (PCC) is used for complete setup, control, image processing and download, and includes tracking and motion analysis tools. Cameras are connected via Gb Ethernet on a dedicated network.

An SDK and Labview drivers are also available for integration for those who require a customized application.

**On-camera controls (OCC)** are standard on VEO S-model cameras and are for use with a connected SDI or HDMI monitor or viewfinder. The OCC menu system allows for setup, capture, playback and saving to a CFast 2.0 card.

**File formats:** The native file format is Phantom Cine RAW (.cine). Cine files can be easily converted to other formats including h.264 mp4, Apple ProRes .mov, AVI, Tiff, JPEG and many more using PCC.

Cine RAW files are also directly compatible with several major video editing and motion analysis programs.

## CFast 2.0 workflow



VEO-S camera models feature compatibility with CFast 2.0 cards, which enable remote and untethered recording. Cine files are first recorded to RAM, and once captured the video can be played back immediately, trimmed and then saved to the CFast 2.0 card. Once on the card the Cine file is safely stored in non-volatile memory and you are free to take your next shot.

- Use standard CFast 2.0 cards, formatted with the NTFS file system.
- Transfer Cine RAW files from RAM to CFast 2.0 at speeds of 90 MB/second.
- Drag-and-drop the saved files using standard USB or Thunderbolt CFast 2.0 card readers on Windows or Mac operating systems.



Phantom VEO-S with monitor and CFast 2.0 card, displaying the on-camera control menu

## Inputs & Outputs

	L-models VEO 410L, 710L, 340L & 640L	S-models VEO 410S, 710S, 340S & 640S
		
Front/Side	SDI: Din port for 3G HD-SDI HDMI: Standard HDMI output VFPWR: 4-pin Hirose for 12V power output, rated for 6W	SDI: Din port for 3G HD-SDI HDMI: Standard HDMI output VFPWR: 4-pin Hirose for 12V power output, rated for 6W
Ethernet	RJ45 for Gb Ethernet	8-pin Fischer for Gb Ethernet
Power Input	6-pin Fischer: 16-32 VDC	6-pin Fischer: 16-32 VDC 12-pin Capture port: Secondary 12V input for battery mount
Capture Port	None	Yes, 12-pin Fischer
Signals	Timecode-in, 2 Programmable I/O	Timecode-in, F-Sync/P, Strobe/P, Ready/P, Timecode-out/P, Range Data
Trigger BNC	Yes	Yes
Rear SDI BNC	None	Yes (3G HD-SDI)
Programmable I/O	2 BNC ports Available signals: Strobe, Event, Pre-trigger, Memgate, Timecode-out, Ready, F-Sync, Aux Trigger, Auto-Trigger	4 BNC ports Available signals: Strobe, Event, Pre-trigger, Memgate, Timecode-out, Ready, F-Sync, Aux Trigger, Auto-Trigger
Serial RS232	Via 6-pin Power	Via 6-pin Power
Range Data	None	Dedicated 6-pin Fischer
On-camera Controls	None	Yes, Encoder knob and buttons for access to menu and control
USB	None	Yes – not active at launch
Removable Media	None	CFast 2.0 cards, NTFS format

Phantom VEO

Example Frame Rates & Record Times

Phantom VEO 710		
Resolution	Maximum Frame Rate	Rec time @ max fps (72GB RAM)
1280 x 800	7400	6.5 seconds
1280 x 720	8200	6.5 seconds
640 x 480	21,000	7.5 seconds
256 x 256	75,000	9 seconds
64 x 8	680,000 (standard)	28 seconds
	1,000,000 (optional*)	15 seconds (optional)

Phantom VEO 410		
Resolution	Maximum Frame Rate	Rec time @ max fps (72GB RAM)
1280 x 800	5200	9.6 seconds
1280 x 720	5800	10 seconds
640 x 480	15,900	11 seconds
256 x 256	57,500	13 seconds
64 x 8	600,000	30 seconds

\*Note: FAST option for VEO 710 models is export controlled

Phantom VEO 640		
Resolution	Maximum Frame Rate	Rec time @ max fps (72GB RAM)
2560 x 1600	1400	8.5 seconds
2560 x 1440	1600	8.6 seconds
1920 x 1080	2800	8.8 seconds
1280 x 720	5700	9.7 seconds
128 x 4	360,000	62 seconds

Phantom VEO 340		
Resolution	Maximum Frame Rate	Rec time @ max fps (72GB RAM)
2560 x 1600	800	15 seconds
2560 x 1440	890	15 seconds
1920 x 1080	1500	15 seconds
1280 x 720	3300	16 seconds
128 x 4	350,000	63 seconds

Record durations shown are for cameras with 72GB of RAM at the maximum frame rate. Cameras with 36GB RAM will record for ½ the duration shown and 18GB RAM provides ¼ the duration. Lower frame rates provide longer record times.

Visit [phantomhighspeed.com/calc](http://phantomhighspeed.com/calc) to use our recording time calculator for more available resolutions and frame rates.

**Vision Research Global Support - for wherever you are**

The Phantom VEO camera line is supported by Vision Research's Global Service and Support network offering AMECare Performance Services from multiple sites around the globe. Maximize the value of your Phantom camera with a full menu of professional support services. Learn more about our service and support options at [www.phantomhighspeed.com/Service-Support](http://www.phantomhighspeed.com/Service-Support)

With up to 72GB of RAM, the Phantom VEO can capture more frames than most. Use multi-cine to segment the memory up to 63 times for fast, uninterrupted capture of shorter events.



# DATA SHEET

## Phantom® VEO Additional Specifications

### Power Requirements:

Primary power: 16-32 VDC via 6-pin fischer  
 Secondary power\*: down to 12 VDC, via 12-pin capture port (S-models only)  
 Power draw at max load: 70 Watts (approx.)

\* When both are connected, the power input with highest voltage gets used first.

### Environmental Specs:

*Operational Temperature: -10°C - +50°C*  
*Operational Shock: MIL-STD-202G Method 213-B. Rated 30G with shutter; 100G without shutter; sawtooth wave, 11ms, +/- 10 pulses all axes (60 total)*  
*Vibration Rating: MIL-STD-202G Method 214-A. Rated 12Grms; Figure 2A-1, Test Condition D, 15 min per axis*  
*Regulatory: EMC/ESD*  
*Emissions: EN61326-1, FCC part 15*  
*Immunity: EN 61326-1*

### Focused

Since 1950, Vision Research has been designing, and manufacturing high-speed cameras. Our single focus is to invent, build, and support the most advanced cameras possible.



100 Dey Road  
 Wayne, NJ 07470 USA  
 +1.973.696.4500

[www.phantomhighspeed.com](http://www.phantomhighspeed.com)

## Mechanical Design

The VEO housing is precision-milled out of solid aluminum, making the camera rugged and stable in tough environments. The camera's cooling system is designed to keep the electrical components completely isolated from the airflow and protected from the outside elements.

## Mechanical Specifications:

### VEO L-models

Size: 5 x 5 x 5 in. (12.7 x 12.7 x 12.7 cm) L x W x H  
 Weight: 5.0 lbs (2.3 kg)

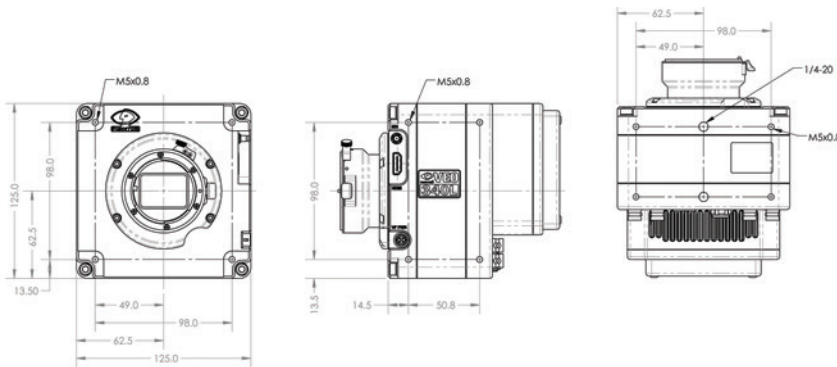

### VEO S-models

Size: 5 x 5.5 x 5 in. (12.7 x 14 x 12.7 cm) L x W x H  
 Weight: 5.6 lbs (2.5 kg)

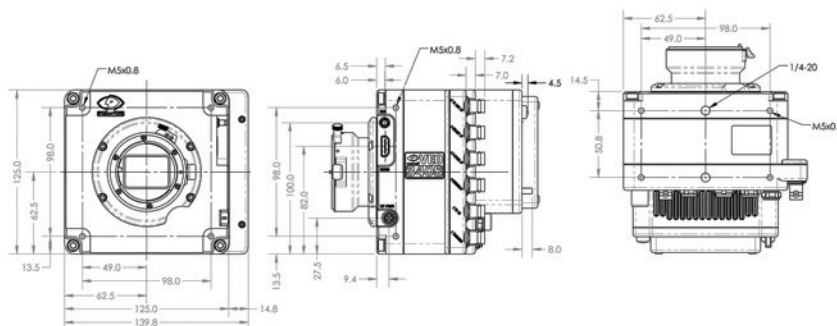

\*size does not include lens mount

AMETEK Vision Research's digital high-speed cameras are subject to the export licensing jurisdiction of the Export Administration Regulations. As a result, the export, transfer, or re-export of these cameras to a country embargoed by the United States is strictly prohibited. Likewise, it is prohibited under the Export Administration Regulations to export, transfer, or re-export AMETEK Vision Research's digital high-speed cameras to certain buyers and/or end users.

Customers are also advised that some models of AMETEK Vision Research's digital high-speed cameras may require a license from the U.S. Department of Commerce to be: (1) exported from the United States; (2) transferred to a foreign person in the United States; or (3) re-exported to a third country. Interested parties should contact the U.S. Department of Commerce to determine if an export or a re-export license is required for their specific transaction.