

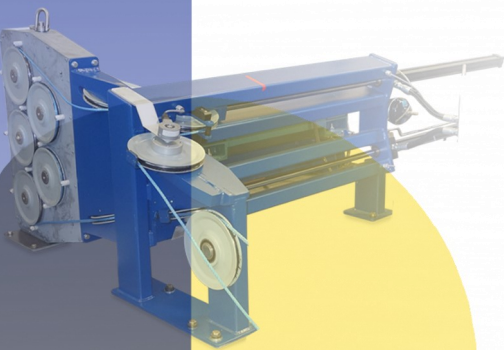

Full Vehicle Crash Test Facility

Seattle Safety Crash Drive with closed loop controlled braking capability—

Whether an upgrade to an existing system or a brand new facility, the team at Seattle Safety has the flexible solution to all your testing needs. From one (1) ton to fifty (50) tons, 2kph to 120kph, Car-to-car, side impact, rear impact, roll-over, curb trip, and even pre-impact braking, Seattle Safety can provide it all.



SEATTLE SAFETY



Pre-Impact Braking

Skate System

- Push OR Pull
- Posts, Chains, or Wire Ropes



Low Profile

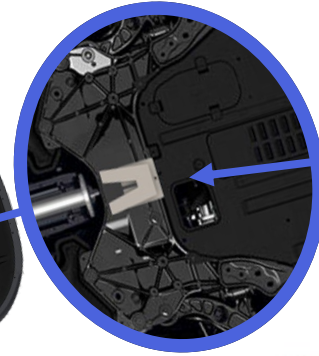
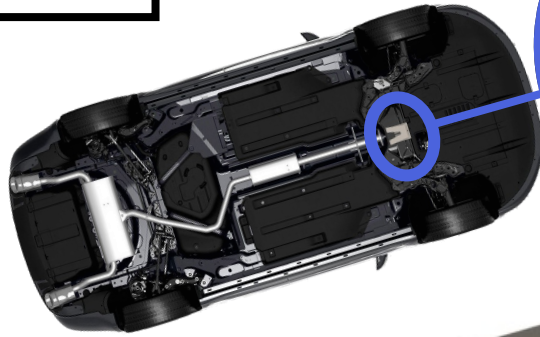

Pushing Post Clip

Drive Rope

- Steel or Polymer with No Loop Splice Application
- Polymer Rope:
 - 21% the weight (compare 46kg to 245kg for 300m length)
 - Easy to thread in multi-angle systems

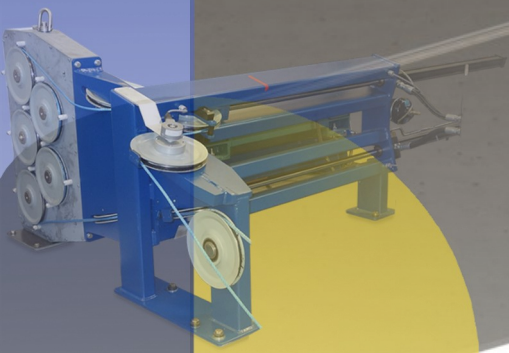

THE FLEXIBLE SOLUTION FROM SEATTLE SAFETY

- Control Systems
- Track Systems
- Fixed Barrier Blocks
- Moving Barrier Blocks
- Moveable Barriers
- Capstan Drives
- Film Pits
- Lighting Systems
- Flying Floors
- Impact Fixtures

EVERYTHING YOU NEED— DESIGNED THE WAY YOU WANT IT!

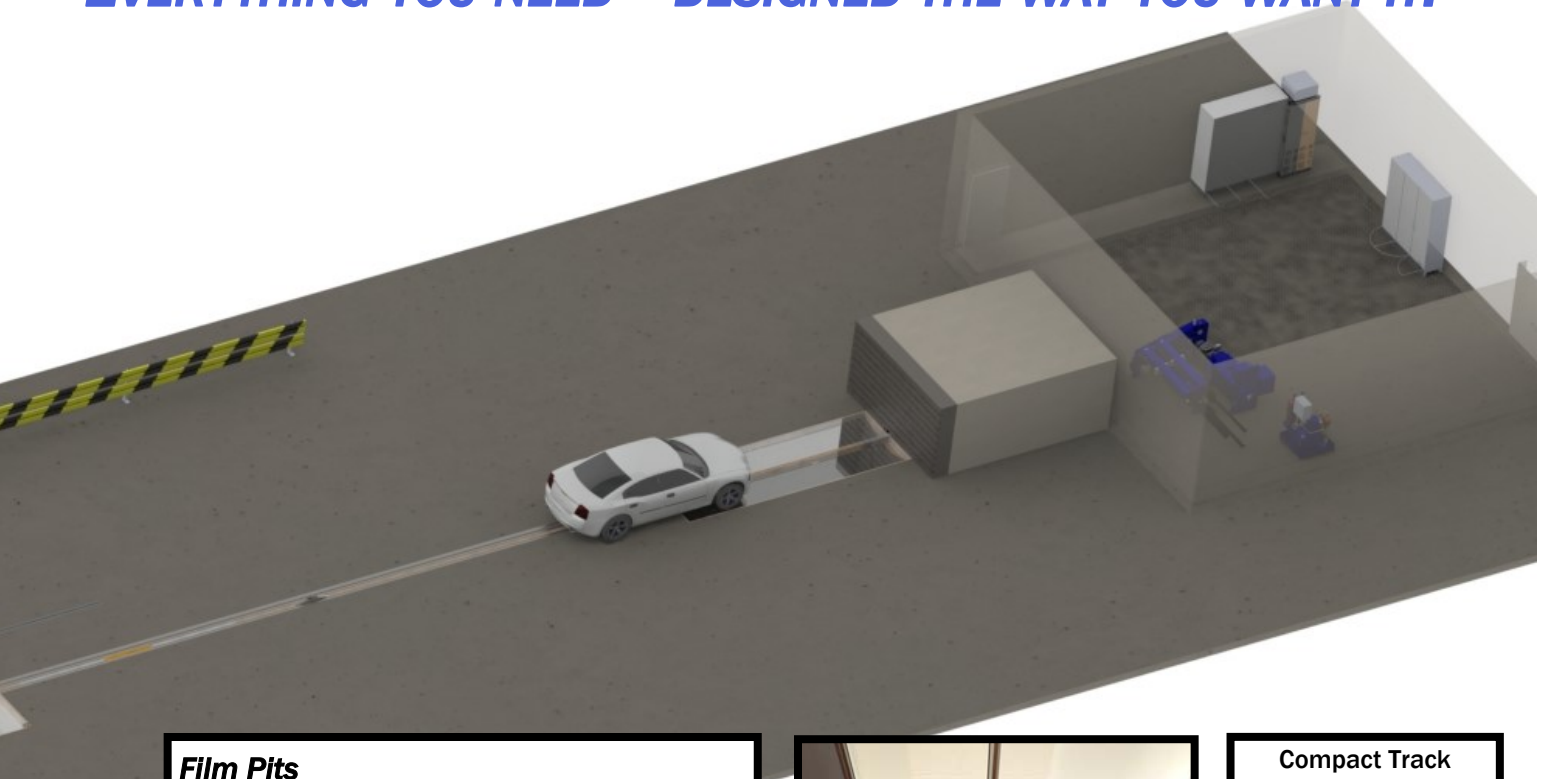

Film Pits

- Cutting-edge Structural Design
 - Clear , Acrylic Panels
 - Concrete Covers
 - Sacrificial Covers
 - Steel Cover Plates
- Optional Automated Concrete Cover Storage

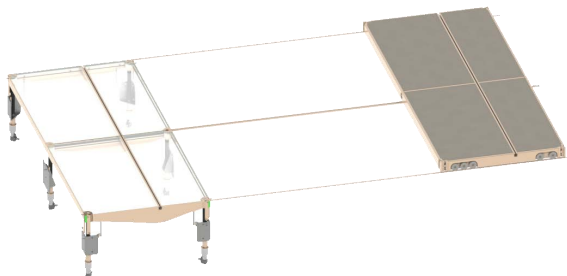

Compact Track Profile for Increased Underbody Viewing. 76mm Rail Width.

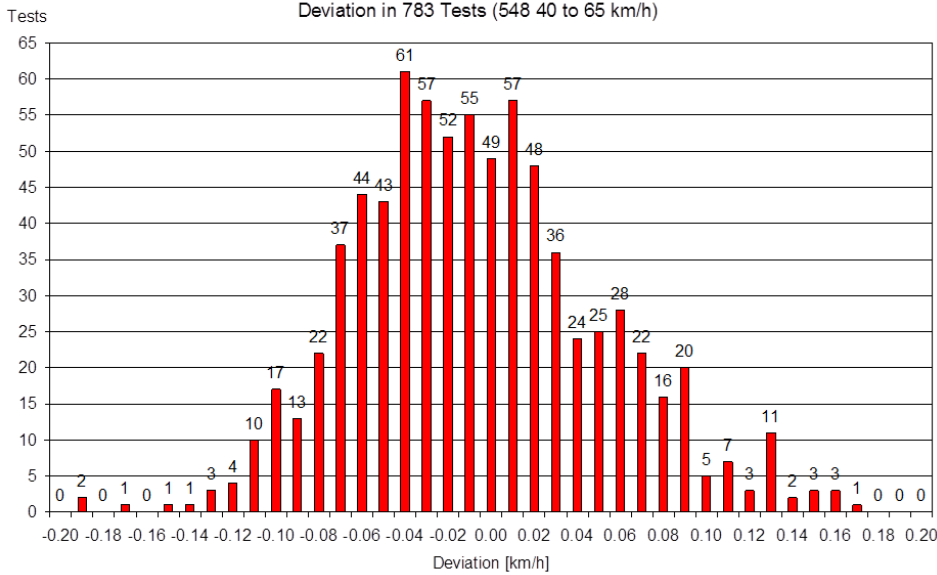

Control System

- High speed accuracy
- 20+ years of experience
- Customized safety plan and security interlocks
- Manual and automatic skate control options

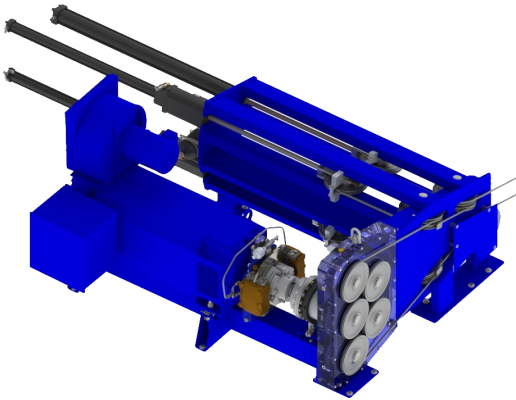

Capstan Drive

- Future expandability
- Closed loop pulling and braking in both directions
 - Gear driven Capstan with 1200° contact area
 - Seamless transition from pulling to braking
 - ◇ Pre-impact braking
 - ◇ Short rope stopping distances
 - ◇ Real-time closed loop motor braking

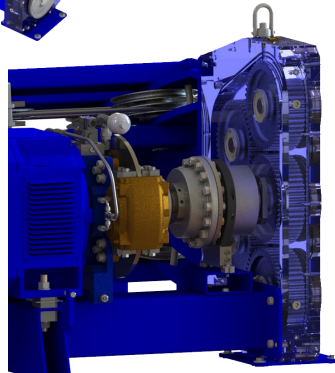

4502 B Street Northwest #1
Auburn Washington 98001
USA
253-395-4321

August-Exter-Straße 37
81245 München
Germany
+49 (0) 172-1492610

www.seattlesafety.com Sales@seattlesafety.com

Any performance data contained herein is operating-condition dependent. Material is confidential and proprietary to Seattle Safety and is not to be disclosed or reproduced in whole or part without prior written agreement from Seattle Safety.